



In Clear Electronics

WWW.IC-1000.COM

THE DATASHEET OF FPGA



www.ic-1000.com



info@ic-1000.com



[+00852-56412601](tel:+00852-56412601)



[+00852-56412601](https://wa.me/0085256412601)



Unit B, 13/F, Shing Lee Commercial Building
No.8 Wing Kut Street, Central HK



Section II. HardCopy APEX Device Family Data Sheet

This section provides designers with the data sheet specifications for HardCopy® APEX™ devices. These chapters contain feature definitions of the internal architecture, configuration and JTAG boundary-scan testing information, DC operating conditions, AC timing parameters, a reference to power consumption, and ordering information for HardCopy APEX devices.

This section contains the following:

- [Chapter 7, Introduction to HardCopy APEX Devices](#)
- [Chapter 8, Description, Architecture, and Features](#)
- [Chapter 9, Boundary-Scan Support](#)
- [Chapter 10, Operating Conditions](#)

Revision History

Refer to each chapter for its own specific revision history. For information on when each chapter was updated, refer to the Chapter Revision Dates section, which appears in the complete handbook.



7. Introduction to HardCopy APEX Devices

H51006-2.3

Introduction

HardCopy® APEX™ devices enable high-density APEX 20KE device technology to be used in high-volume applications where significant cost reduction is desired. HardCopy APEX devices are physically and functionally compatible with APEX 20KC and APEX 20KE devices. They combine the time-to-market advantage, performance, and flexibility of APEX 20KE devices with the ability to move to high-volume, low-cost devices for production. The migration process from an APEX 20KE device to a HardCopy APEX device is fully automated, with designer involvement limited to providing a few Quartus® II software-generated output files.

Features...

HardCopy APEX devices are manufactured using an 0.18- μm CMOS six-layer-metal process technology:

- Preserves functionality of a configured APEX 20KC or APEX 20KE device
- Pin-compatible with APEX 20KC or APEX 20KE devices
- Meets or exceeds timing of configured APEX 20KE and APEX 20KC devices
- Optional emulation of original programmable logic device (PLD) programming sequence
- High-performance, low-power device
- MultiCore architecture integrating embedded memory and look-up table (LUT) logic used for register-intensive functions
- Embedded system blocks (ESBs) used to implement memory functions, including first-in first-out (FIFO) buffers, dual-port RAM, and content-addressable memory (CAM)
- Customization performed through metallization layers

High-density architecture:

- 400,000 to 1.5 million typical gates (Table 7-1)
- Up to 51,840 logic elements (LEs)
- Up to 442,368 RAM bits that can be used without reducing available logic

Feature	HC20K400	HC20K600	HC20K1000	HC20K1500
Maximum system gates	1,052,000	1,537,000	1,772,000	2,392,000
Typical gates	400,000	600,000	1,000,000	1,500,000
LEs	16,640	24,320	38,400	51,840
ESBs	104	152	160	216
Maximum RAM bits	212,992	311,296	327,680	442,368
Phase-locked loops (PLLs)	4	4	4	4
Maximum macrocells	1,664	2,432	2,560	3,456
Maximum user I/O pins	488	588	708	808

Note to Table 7-1:

- (1) The embedded IEEE Std. 1149.1 Joint Test Action Group (JTAG) boundary-scan circuitry contributes up to 57,000 additional gates.

...and More Features

Low-power operation:

- 1.8-V supply voltage (Table 7-2)
- MultiVolt I/O support for 1.8-, 2.5-, and 3.3-V interfaces
- ESBs offering power-saving mode

Flexible clock management circuitry with up to four phase-locked loops (PLLs):

- Built-in low-skew clock tree
- Up to eight global clock signals
- ClockLock feature reducing clock delay and skew
- ClockBoost feature providing clock multiplication and division
- ClockShift feature providing clock phase and delay shifting

Powerful I/O features:

- Compliant with peripheral component interconnect Special Interest Group (PCI SIG) *PCI Local Bus Specification, Revision 2.2* for 3.3-V operation at 33 or 66 MHz and 32 or 64 bits

- Support for high-speed external memories, including double-data rate (DDR), synchronous dynamic RAM (SDRAM), and zero-bus-turnaround (ZBT) static RAM (SRAM)
- 16 input and 16 output LVDS channels
- Fast t_{CO} and t_{SU} times for complex logic
- MultiVolt I/O support for 1.8-V, 2.5-V, and 3.3-V interfaces
- Individual tri-state output enable control for each pin
- Output slew-rate control to reduce switching noise
- Support for advanced I/O standards, including LVDS, LVPECL, PCI-X, AGP, CTT, SSTL-3 and SSTL-2, GTL+, and HSTL Class I
- Supports hot-socketing operation

Table 7-2. HardCopy APEX Device Supply Voltages

Feature	Voltage
Internal supply voltage (V_{CCINT})	1.8 V
MultiVolt I/O interface voltage levels (V_{CCIO})	1.8 V, 2.5 V, 3.3 V, 5.0 V (1)

Note to Table 7-2:

(1) HardCopy APEX devices can be 5.0-V tolerant by using an external resistor.

HardCopy APEX device implementation features:

- Customized interconnect for each design
- HardCopy APEX devices preserve APEX 20K device MegaLAB structure, LEs, ESBs, I/O element (IOE), PLLs, and LVDS circuitry
- Up to four metal layers customizable for customer designs
- Completely automated proprietary design migration flow
 - Testability analysis and fix
 - Automatic test pattern generation (ATPG)
 - Automatic place and route
 - Static timing analysis
 - Static functional verification
 - Physical verification

Tables 7-3 through 7-6 show the HardCopy APEX device ball-grid array (BGA) and FineLine BGA package options, I/O counts, and sizes.

Table 7-3. HardCopy APEX Device BGA Package Options and I/O Count
Note (1)

Device	652-Pin BGA
HC20K400	488
HC20K600	488
HC20K1000	488
HC20K1500	488

Table 7-4. HardCopy APEX Device FineLine BGA Package Options and I/O Count
Note (1)

Device	672-Pin	1,020-Pin
HC20K400	488	–
HC20K600	508	588
HC20K1000	508	708
HC20K1500	–	808

Note to Tables 7-3 and 7-4:

- (1) I/O counts include dedicated input and clock pins.

Table 7-5. HardCopy APEX Device BGA Package Sizes

Feature	652-Pin BGA
Pitch (mm)	1.27
Area (mm ²)	2,025
Length × width (mm × mm)	45.0 × 45.0

Table 7-6. HardCopy APEX Device FineLine BGA Package Sizes

Feature	672-Pin	1,020-Pin
Pitch (mm)	1.00	1.00
Area (mm ²)	729	1,089
Length × width (mm × mm)	27 × 27	33 × 33

Document Revision History

Table 7-7 shows the revision history for this chapter.

Date and Document Version	Changes Made	Summary of Changes
September 2008, v2.3	Updated chapter number and metadata.	—
June 2007, v2.2	Minor text edits.	—
December 2006 v2.1	Updated revision history.	—
March 2006	Formerly chapter 9; no content change.	—
January 2005 v2.0	Update device names and other minor textual changes	—
June 2003 v1.0	Initial release of Chapter 9, <i>Introduction to HardCopy APEX Devices</i> , in the <i>HardCopy Device Handbook</i>	—



8. Description, Architecture, and Features

H51007-2.3

Introduction

HardCopy® APEX™ devices extend the flexibility of high-density FPGAs to a cost-effective, high-volume production solution. The migration process from an Altera® FPGA to a HardCopy APEX device offers seamless migration of a high-density system-on-a-programmable-chip (SOPC) design to a low-cost alternative device with minimal risk. Using HardCopy APEX devices, Altera's SOPC solutions can be leveraged from prototype to production, while reducing costs and speeding time-to-market.

A significant benefit of HardCopy devices is that customers do not need to be involved in the device migration process. Unlike application-specific integrated circuit (ASIC) development, the HardCopy design flow does not require generation of test benches, test vectors, or timing and functional simulation. The HardCopy migration process only requires the Quartus® II software-generated output files from a fully functional APEX 20KE or APEX 20KC device. Altera performs the migration and delivers functional prototypes in as few as seven weeks.

A risk-free alternative to ASICs, HardCopy APEX devices are customizable, full-featured devices created by Altera's proprietary design migration methodology. They are based on Altera's industry-leading high-density device architecture and use an area-efficient sea-of-logic-elements (SOLE) core.

HardCopy APEX devices retain all the same features as the APEX 20KE and APEX 20KC devices, which combine the strength of LUT-based and product-term-based devices in conjunction with the same embedded memory structures. All routing resources that were programmable in the APEX 20K device family are replaced by custom interconnect, resulting in a considerable die size reduction and subsequent cost saving.

The SRAM configuration cells of the original FPGA are replaced in HardCopy APEX devices by metal elements, which define the function of each logic element (LE), embedded memory, and I/O cell in the device. These resources are connected to each other using the same metallization layers. Once a HardCopy APEX device has been manufactured, the functionality of the device is fixed and no programming is possible. Altera performs the migration of the original FPGA design to an equivalent HardCopy APEX device using a proprietary design migration flow.

The migration of a FPGA to a HardCopy APEX device begins with a user design that has been implemented in an APEX 20KE or APEX 20KC device. [Table 8-1](#) shows the device equivalence for HardCopy and APEX 20KE or APEX 20KC devices.

Table 8-1. HardCopy and APEX 20KE or APEX 20C Device Equivalence

HardCopy APEX Device	APEX 20KE Device	APEX 20KC Device
HC20K1500	EP20K1500E	EP20K1500C
HC20K1000	EP20K1000E	EP20K1000C
HC20K600	EP20K600E	EP20K600C
HC20K400	EP20K400E	EP20K400C



To ensure HardCopy device performance and functionality, the APEX 20K design must be completely debugged before committing the design to HardCopy device migration.

HardCopy APEX device implementation begins with extracting the Quartus II software-generated SRAM Object File (.sof) and converting its connectivity information into a structural Verilog HDL netlist. This netlist is then placed and routed in a similar fashion to a gate array. There are no dedicated routing channels. The router can exploit all available metal layers (up to four) and route over LE cells and other functional blocks. Altera’s proprietary architecture and design methodology will guarantee virtually 100% routing of any APEX 20KE or APEX 20KC design compiled and fitted successfully using the Quartus II software. Place and route is timing-driven and will comply with the timing constraints of the original FPGA design as specified in the Quartus II software. [Figure 8-1](#) shows a diagram of the HardCopy APEX device architecture.

Figure 8–1. HardCopy APEX Device Architecture

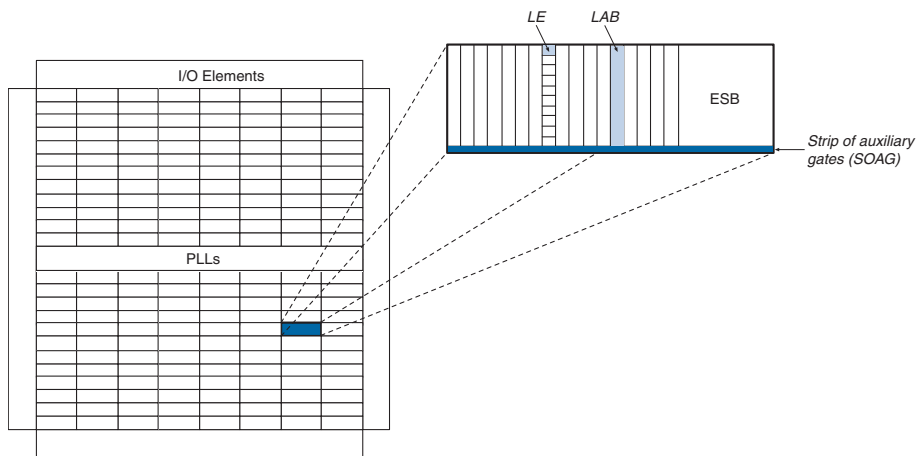

The strip of auxiliary gates (SOAG) is an Altera proprietary feature designed into the HardCopy APEX device and is used during the HardCopy device implementation process. The SOAG structures can be configured into several different types of functions through the use of metallization. For example, high fanout signals require adequate buffering, so buffers are built out of SOAG cells for this purpose.

HardCopy APEX devices include the same advanced features as the APEX 20KE and APEX 20KC devices, such as enhanced I/O standard support, content-addressable memory (CAM), additional global clocks, and enhanced ClockLock circuitry. [Table 8–2](#) lists the features included in HardCopy APEX devices.

Table 8–2. HardCopy APEX Device Features (Part 1 of 2)

Feature	HardCopy Devices
MultiCore system integration	Full support
Hot-socketing support	Full support
32-/64-bit, 33-MHz PCI	Full compliance
32-/64-bit, 66-MHz PCI	Full compliance
MultiVolt I/O operation	1.8-V, 2.5-V, or 3.3-V V_{CCIO} V_{CCIO} selected bank by bank 5.0-V tolerant with use of external resistor

Table 8–2. HardCopy APEX Device Features (Part 2 of 2)	
Feature	HardCopy Devices
ClockLock support	Clock delay reduction $m/(n \times v)$ clock multiplication Drive ClockLock output off-chip External clock feedback ClockShift circuitry LVDS support Up to four PLLs ClockShift, clock phase adjustment
Dedicated clock and input pins	Eight
I/O standard support	1.8-V, 2.5-V, 3.3-V, 5.0-V I/O 3.3-V PCI and PCI-X 3.3-V AGP CTT GTL+ LVCMOS LVTTTL True-LVDS and LVPECL data pins LVDS and LVPECL clock pins HSTL class I PCI-X SSTL-2 class I and II SSTL-3 class I and II
Memory support	CAM Dual-port RAM FIFO RAM ROM

All HardCopy APEX devices are tested using automatic test pattern generation (ATPG) vectors prior to shipment. For fully synchronous designs near 100%, fault coverage can be achieved through the built-in full-scan architecture. ATPG vectors allow the designer to focus on simulation and design verification.

Because the configuration of HardCopy APEX devices is built-in during manufacture, they cannot be configured in-system. However, if the APEX 20KE or APEX 20KC device configuration sequence must be emulated, the HardCopy APEX device has this capability.



All of the device features of APEX 20KE and APEX 20KC devices are available in HardCopy APEX devices. For a detailed description of these device features, refer to the *APEX 20K Programmable Logic Device Family Data Sheet* and the *APEX 20KC Programmable Logic Device Family Data Sheet*.

Differences Between HardCopy APEX and APEX 20K FPGAs

Several differences must be considered before a design is ready for implementation in HardCopy technology:

- HardCopy APEX devices are only customizable at the time they are manufactured. Make sure that the original APEX 20KE or APEX 20KC device has undergone thorough testing in the end-system before deciding to proceed with migration to a HardCopy APEX device, because no changes can be made to the HardCopy APEX device after it has been manufactured.
- ESBs that are configured as RAM or CAM will power-up un-initialized in the HardCopy APEX device. In the FPGA it is possible to configure, or “pre-load,” the ESB memory as part of the configuration sequence, then overwrite it when the device is in normal functional mode. This pre-loaded memory feature of the FPGA is not available in HardCopy devices. If a design contains RAM or CAM with assumed data values at power-up, then the HardCopy APEX device will not operate as expected. If a design uses this feature, it should be re-compiled without the memory pre-load. ESBs configured as ROM are fully supported.
- The JTAG boundary scan order in the HardCopy APEX device is different compared to the APEX 20K device. A HardCopy BSDL file that describes the re-ordered boundary scan chain should be used.



The BSDL files for HardCopy APEX devices are different from the corresponding APEX 20KE or APEX 20KC devices. Download the correct HardCopy BSDL file from Altera’s website at www.altera.com.

- The advanced 0.18- μ m aluminum metal process is used to support both APEX 20KE and APEX 20KC devices. The performance improvement achieved by the die size reduction and metal interconnect optimization more than offsets the need for copper in this case. Altera guarantees that a target HardCopy APEX device will provide the same or better performance as in the corresponding APEX 20KE or APEX 20KC device.

Power-up Mode and Configuration Emulation

Unlike their FPGA counterparts, HardCopy APEX devices do not need to be configured. However, to facilitate seamless migration, configuration can be emulated in these devices. There are three modes in which a

HardCopy APEX device can be prepared for operation after power up: instant on, instant on after 50 ms, and configuration emulation. Each mode is described below.

- In instant on mode, the HardCopy APEX device is available for use shortly after the device receives power. The on-chip power-on-reset (POR) circuit will set or reset all registers. The `CONF_DONE` output will be tri-stated once the power-on reset has elapsed. No configuration device or configuration input signals are necessary.
- In instant on after 50 ms mode, the HardCopy APEX device performs in a similar fashion to the Instant On mode, except that there is an additional delay of 50 ms (nominal), during which time the device is held in reset stage. The `CONF_DONE` output is pulled low during this time and then tri-stated after the 50 ms have elapsed. No configuration devices or configuration input signals are necessary for this option.
- In configuration emulation mode, the HardCopy APEX device undergoes an emulation of a full configuration sequence as if configured by an external processor or an EPC device. In this mode, the `CONF_DONE` signal is tri-stated after the correct number of clock cycles. This mode may be useful where there is some dependency on the configuration sequence (for example, multi-device configuration or processor initialization). In this mode, the device expects to see all configuration control and data input signals.

Speed Grades

Because HardCopy APEX devices are customized, no speed grading is performed. All HardCopy APEX devices will meet the timing requirements of the original FPGA of the fastest speed grade. Generally, HardCopy APEX devices will have a higher f_{MAX} than the corresponding FPGA, but the speed increase will vary on a design-by-design basis.

Quartus II-Generated Output Files

The HardCopy migration process requires several Quartus II software-generated files. These key output files are listed and explained below.

- The SRAM Object File (`.sof`) contains all of the necessary information needed to configure a FPGA
- The Compiler Report File (`.csf.rpt`) is parsed to extract useful information about the design
- The Verilog atom-based netlist file (`.vo`) is used to check the HardCopy netlist
- The pin out information file (`.pin`) contains user signal names and I/O configuration information

- The Delay Information File (.sdo) is used to check the original FPGA timing
- A completed HardCopy timing requirements file describes all necessary timing information on the design. A template of this text file is available for download from the Altera website at www.altera.com.

The migration process consists of several steps. First, a netlist is constructed from the SOF. Then, the netlist is checked to ensure that the built-in scan test structures will operate correctly. The netlist is then fed into a place-and-route engine, and the design interconnect is generated. Static timing analysis ensures that all timing constraints are met, and static functional verification techniques are employed to ensure correct device migration. After successfully completing these stages, physical verification of the device takes place, and the metal mask layers are taped out to fabricate HardCopy APEX devices.

Document Revision History

Table 8-3 shows the revision history for this chapter.

<i>Table 8-3. Document Revision History</i>		
Date and Document Version	Changes Made	Summary of Changes
September 2008, v2.3	Updated chapter number and metadata.	—
June 2007, v2.2	Minor text edits.	—
December 2006 v2.1	Updated revision history.	—
March 2006	Formerly chapter 10; no content change.	—
January 2005 v2.0	Update device names and other minor textual changes	—
June 2003 v1.0	Initial release of Chapter 10, <i>Description, Architecture and Features</i> , in the HardCopy Device Handbook	—



9. Boundary-Scan Support

H51009-2.3

IEEE Std. 1149.1 (JTAG) Boundary-Scan Support

All HardCopy devices provide JTAG boundary-scan test (BST) circuitry that complies with the IEEE Std. 1149.1-1990 specification. HardCopy[®] APEX[™] devices support the JTAG instructions shown in [Table 9–1](#).



The BSDL files for HardCopy devices are different from the corresponding APEX 20KE or APEX 20KC parts. Download the correct HardCopy BSDL file from Altera’s website at www.altera.com.

Table 9–1. HardCopy APEX JTAG Instructions

JTAG Instruction	Description
SAMPLE/PRELOAD	SAMPLE/PRELOAD allows a snapshot of signals at the device pins to be captured and examined during normal device operation and permits an initial data pattern to be output at the device pins. It is also used by the SignalTap [®] embedded logic analyzer.
EXTEST	Allows the external circuitry and board-level interconnections to be tested by forcing a test pattern at the output pins and capturing test results at the input pins.
BYPASS	Places the 1-bit bypass register between the TDI and TDO pins, which allows the BST data to pass synchronously through selected devices to adjacent devices during normal device operation.
USERCODE	Selects the 32-bit USERCODE register and places it between the TDI and TDO pins, allowing the USERCODE to be serially shifted out of TDO.
IDCODE	Selects the IDCODE register and places it between the TDI and TDO pins, allowing the IDCODE to be serially shifted out of TDO.

HardCopy APEX devices instruction register length is 10 bits; the USERCODE register length is 32 bits. [Tables 9–2](#) and [9–3](#) show the boundary-scan register length and device IDCODE information for HardCopy devices.

Table 9–2. HardCopy APEX Boundary-Scan Register Length

Device	Boundary-Scan Register Length
HC20K400	1,506
HC20K600	1,806
HC20K1000	2,190
HC20K1500	2,502

Table 9–3. 32-Bit HardCopy APEX Device IDCODE

Device	IDCODE (32 Bits) <i>Note (1)</i>			
	Version (4 Bits)	Part Number (16 Bits)	Manufacturer Identity (11 Bits)	1 (1 Bit) (2)
HC20K400	0000	1000 0100 0000 0000	000 0110 1110	1
HC20K600	0000	1000 0110 0000 0000	000 0110 1110	1
HC20K1000	0000	1001 0000 0000 0000	000 0110 1110	1
HC20K1500	0000	1001 0101 0000 0000	000 0110 1110	1

Notes to Table 9–3:

- (1) The most significant bit (MSB) is on the left.
- (2) The IDCODE's least significant bit (LSB) is always 1.

Figure 9–1 shows the timing requirements for the JTAG signals.

Figure 9–1. HardCopy JTAG Waveforms

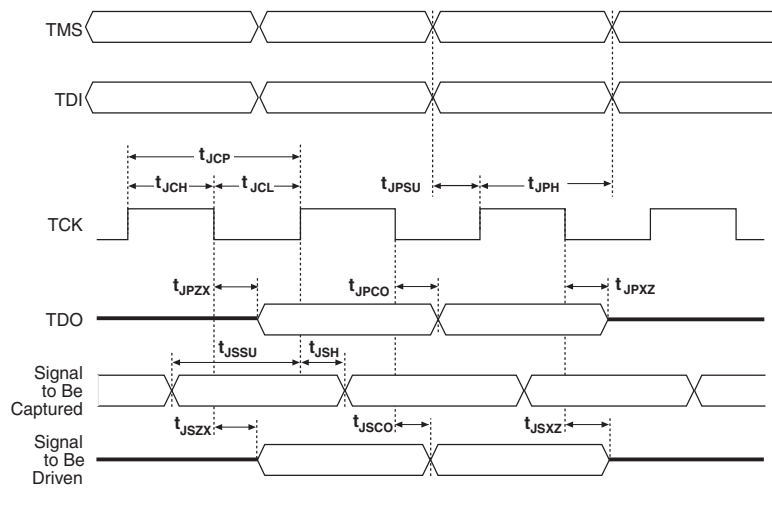

Table 9–4 shows the JTAG timing parameters and values for HardCopy devices.

Table 9–4. HardCopy APEX JTAG Timing Parameters and Values

Symbol	Parameter	Min	Max	Unit
t_{JCP}	TCK clock period	100		ns
t_{JCH}	TCK clock high time	50		ns
t_{JCL}	TCK clock low time	50		ns
t_{JPSU}	JTAG port setup time	20		ns
t_{JPH}	JTAG port hold time	45		ns
t_{JPCO}	JTAG port clock to output		25	ns
t_{JPZX}	JTAG port high impedance to valid output		25	ns
t_{JPXZ}	JTAG port valid output to high impedance		25	ns
t_{JSSU}	Capture register setup time	20		ns
t_{JSH}	Capture register hold time	45		ns
t_{JSCO}	Update register clock to output		35	ns
t_{JSZX}	Update register high impedance to valid output		35	ns
t_{JSXZ}	Update register valid output to high impedance		35	ns



For more information about using JTAG BST circuitry in Altera devices, refer to *Application Note 39 (IEEE Std. 1149.1 (JTAG) Boundary-Scan Testing in Altera Devices)*.

Document Revision History

Table 9–5 shows the revision history for this chapter.

Table 9–5. Document Revision History (Part 1 of 2)

Date and Document Version	Changes Made	Summary of Changes
September 2008, v2.3	Updated chapter number and metadata.	—
June 2007, v2.2	Minor text edits.	—
December 2006 v2.1	Updated revision history.	Updated revision history.
March 2006	Formerly chapter 11; no content change.	

Table 9–5. Document Revision History (Part 2 of 2)

Date and Document Version	Changes Made	Summary of Changes
January 2005 v2.0	Update device names and other minor textual changes.	—
June 2003 v1.0	Initial release of <i>Boundary-Scan Support</i> in the HardCopy Device Handbook.	—



10. Operating Conditions

H51010-2.3

Recommended Operating Conditions

Tables 10–1 through 10–4 provide information on absolute maximum ratings, recommended operating conditions, DC operating conditions, and capacitance for 1.8-V HardCopy® APEX™ devices.

Table 10–1. HardCopy APEX Device Absolute Maximum Ratings *Note (1)*

Symbol	Parameter	Conditions	Min	Max	Unit
V_{CCINT}	Supply voltage	With respect to ground (2)	–0.5	2.5	V
V_{CCIO}			–0.5	4.6	V
V_I			–0.5	4.6	V
I_{OUT}	DC output current, per pin		–25	25	mA
T_{STG}	Storage temperature	No bias	–65	150	°C
T_{AMB}	Ambient temperature	Under bias	–65	135	°C
T_J	Junction temperature	BGA packages, under bias		135	°C

Table 10–2. HardCopy APEX Device Recommended Operating Conditions

Symbol	Parameter	Conditions	Min	Max	Unit
V_{CCINT}	Supply voltage for internal logic and input buffers	(3), (4)	1.71 (1.71)	1.89 (1.89)	V
V_{CCIO}	Supply voltage for output buffers, 3.3-V operation	(3), (4)	3.00 (3.00)	3.60 (3.60)	V
	Supply voltage for output buffers, 2.5-V operation	(3), (4)	2.375 (2.375)	2.625 (2.625)	V
V_I	Input voltage	(2), (5)	–0.5	4.1	V
V_O	Output voltage		0	V_{CCIO}	V
T_J	Junction temperature	For commercial use	0	85	°C
		For industrial use	–40	100	°C
t_R	Input rise time (10% to 90%)			40	ns
t_F	Input fall time (90% to 10%)			40	ns

Table 10–3. HardCopy APEX Device DC Operating Conditions (Part 1 of 2) Notes (6), (7), (8)

Symbol	Parameter	Conditions	Min	Typ	Max	Unit	
V_{IH}	High-level LVTTTL, CMOS, or 3.3-V PCI input voltage		1.7, $0.5 \times V_{CCIO}$ (8)		4.1	V	
V_{IL}	Low-level LVTTTL, CMOS, or 3.3-V PCI input voltage		-0.5		0.8, $0.3 \times V_{CCIO}$ (8)	V	
V_{OH}	3.3-V high-level LVTTTL output voltage	$I_{OH} = -12$ mA DC, $V_{CCIO} = 3.00$ V (9)	2.4			V	
	3.3-V high-level LVCMOS output voltage	$I_{OH} = -0.1$ mA DC, $V_{CCIO} = 3.00$ V (9)	$V_{CCIO} - 0.2$			V	
	3.3-V high-level PCI output voltage	$I_{OH} = -0.5$ mA DC, $V_{CCIO} = 3.00$ to 3.60 V (9)	$0.9 \times V_{CCIO}$			V	
	2.5-V high-level output voltage	$I_{OH} = -0.1$ mA DC, $V_{CCIO} = 2.30$ V (9)	2.1			V	
		$I_{OH} = -1$ mA DC, $V_{CCIO} = 2.30$ V (9)	2.0			V	
		$I_{OH} = -2$ mA DC, $V_{CCIO} = 2.30$ V (9)	1.7			V	
	V_{OL}	3.3-V low-level LVTTTL output voltage	$I_{OL} = 12$ mA DC, $V_{CCIO} = 3.00$ V (10)			0.4	V
3.3-V low-level LVCMOS output voltage		$I_{OL} = 0.1$ mA DC, $V_{CCIO} = 3.00$ V (10)			0.2	V	
3.3-V low-level PCI output voltage		$I_{OL} = 1.5$ mA DC, $V_{CCIO} = 3.00$ to 3.60 V (10)			$0.1 \times V_{CCIO}$	V	
2.5-V low-level output voltage		$I_{OL} = 0.1$ mA DC, $V_{CCIO} = 2.30$ V (10)				0.2	V
		$I_{OL} = 1$ mA DC, $V_{CCIO} = 2.30$ V (10)				0.4	V
		$I_{OL} = 2$ mA DC, $V_{CCIO} = 2.30$ V (10)				0.7	V
I_I		Input pin leakage current (11)	$V_I = 4.1$ to -0.5 V	-10		10	μ A
I_{OZ}	Tri-stated I/O pin leakage current (11)	$V_O = 4.1$ to -0.5 V	-10		10	μ A	
I_{CC0}	V_{CC} supply current (standby) (All ESBs in power-down mode)	$V_I =$ ground, no load, no toggling inputs, -7 speed grade		10		mA	
		$V_I =$ ground, no load, no toggling inputs, -8, -9 speed grades		5		mA	

Table 10–3. HardCopy APEX Device DC Operating Conditions (Part 2 of 2) Notes (6), (7), (8)

Symbol	Parameter	Conditions	Min	Typ	Max	Unit
R _{CONF}	Value of I/O pin pull-up resistor before and during configuration emulation	V _{CCIO} = 3.0 V (12)	20		50	kΩ
		V _{CCIO} = 2.375 V (12)	30		80	kΩ
		V _{CCIO} = 1.71 V (12)	60		150	kΩ

Table 10–4. HardCopy APEX Device Capacitance Note (13)

Symbol	Parameter	Conditions	Min	Typ	Max
C _{IN}	Input capacitance	V _{IN} = 0 V, f = 1.0 MHz		8	pF
C _{INCLK}	Input capacitance on dedicated clock pin	V _{IN} = 0 V, f = 1.0 MHz		12	pF
C _{OUT}	Output capacitance	V _{OUT} = 0 V, f = 1.0 MHz		8	pF

Notes to Table 10–1 through 10–4:

- (1) Refer to the *Operating Requirements for Altera Devices Data Sheet*.
- (2) Minimum DC input is –0.5 V. During transitions, the inputs may undershoot to –0.5 V or overshoot to 4.6 V for input currents less than 100 mA and periods shorter than 20 ns.
- (3) Numbers in parentheses are for industrial-temperature-range devices.
- (4) Maximum V_{CC} rise time is 100 ms, and V_{CC} must rise monotonically.
- (5) All pins (including dedicated inputs, clock, I/O, and JTAG pins) may be driven before V_{CCINT} and V_{CCIO} are powered.
- (6) Typical values are for T_A = 25°C, V_{CCINT} = 1.8 V, and V_{CCIO} = 1.8 V, 2.5 V, or 3.3 V.
- (7) These values are specified under the HardCopy device recommended operating conditions, as shown in [Table 10–2 on page 10–1](#).
- (8) Refer to *AN 117: Using Selectable I/O Standards in Altera Devices* for the V_{IH}, V_{IL}, V_{OH}, V_{OL}, and I_I parameters when V_{CCIO} = 1.8 V.
- (9) The APEX 20KE input buffers are compatible with 1.8-V, 2.5-V and 3.3-V (LVTTTL and LVCMOS) signals. Additionally, the input buffers are 3.3-V PCI compliant. Input buffers also meet specifications for GTL+, CTT, AGP, SSTL-2, SSTL-3, and HSTL.
- (10) The I_{OH} parameter refers to high-level TTL, PCI, or CMOS output current.
- (11) This value is specified for normal device operation. The value may vary during power-up.
- (12) Pin pull-up resistance values will be lower if an external source drives the pin higher than V_{CCIO}.
- (13) Capacitance is sample-tested only.

Tables 10–5 through 10–20 list the DC operating specifications for the supported I/O standards. These tables list minimal specifications only; HardCopy devices may exceed these specifications.

Table 10–5. LVTTTL I/O Specifications

Symbol	Parameter	Conditions	Minimum	Maximum	Units
V_{CCIO}	Output supply voltage		3.0	3.6	V
V_{IH}	High-level input voltage		2.0	$V_{CCIO} + 0.3$	V
V_{IL}	Low-level input voltage		-0.3	0.8	V
I_I	Input pin leakage current	$V_{IN} = 0\text{ V or }3.3\text{ V}$	-10	10	μA
V_{OH}	High-level output voltage	$I_{OH} = -12\text{ mA}$, $V_{CCIO} = 3.0\text{ V}$ (1)	2.4		V
V_{OL}	Low-level output voltage	$I_{OL} = 12\text{ mA}$, $V_{CCIO} = 3.0\text{ V}$ (2)		0.4	V

Table 10–6. LVC MOS I/O Specifications

Symbol	Parameter	Conditions	Minimum	Maximum	Units
V_{CCIO}	Power supply voltage range		3.0	3.6	V
V_{IH}	High-level input voltage		2.0	$V_{CCIO} + 0.3$	V
V_{IL}	Low-level input voltage		-0.3	0.8	V
I_I	Input pin leakage current	$V_{IN} = 0\text{ V or }3.3\text{ V}$	-10	10	μA
V_{OH}	High-level output voltage	$V_{CCIO} = 3.0\text{ V}$ $I_{OH} = -0.1\text{ mA}$ (1)	$V_{CCIO} - 0.2$		V
V_{OL}	Low-level output voltage	$V_{CCIO} = 3.0\text{ V}$ $I_{OL} = 0.1\text{ mA}$ (2)		0.2	V

Table 10–7. 2.5-V I/O Specifications

Symbol	Parameter	Conditions	Minimum	Maximum	Units
V_{CCIO}	Output supply voltage		2.375	2.625	V
V_{IH}	High-level input voltage		1.7	$V_{CCIO} + 0.3$	V
V_{IL}	Low-level input voltage		-0.3	0.7	V
I_I	Input pin leakage current	$V_{IN} = 0\text{ V or }3.3\text{ V}$	-10	10	μA
V_{OH}	High-level output voltage	$I_{OH} = -0.1\text{ mA (1)}$	2.1		V
		$I_{OH} = -1\text{ mA (1)}$	2.0		V
		$I_{OH} = -2\text{ mA (1)}$	1.7		V
V_{OL}	Low-level output voltage	$I_{OL} = 0.1\text{ mA (2)}$		0.2	V
		$I_{OL} = 1\text{ mA (2)}$		0.4	V
		$I_{OL} = 2\text{ mA (2)}$		0.7	V

Table 10–8. 1.8-V I/O Specifications

Symbol	Parameter	Conditions	Minimum	Maximum	Units
V_{CCIO}	Output supply voltage		1.7	1.9	V
V_{IH}	High-level input voltage		$0.65 \times V_{CCIO}$	$V_{CCIO} + 0.3$	V
V_{IL}	Low-level input voltage			$0.35 \times V_{CCIO}$	V
I_I	Input pin leakage current	$V_{IN} = 0\text{ V or }3.3\text{ V}$	-10	10	μA
V_{OH}	High-level output voltage	$I_{OH} = -2\text{ mA (1)}$	$V_{CCIO} - 0.45$		V
V_{OL}	Low-level output voltage	$I_{OL} = 2\text{ mA (2)}$		0.45	V

Table 10–9. 3.3-V PCI Specifications (Part 1 of 2)

Symbol	Parameter	Conditions	Minimum	Typical	Maximum	Units
V_{CCIO}	I/O supply voltage		3.0	3.3	3.6	V
V_{IH}	High-level input voltage		$0.5 \times V_{CCIO}$		$V_{CCIO} + 0.5$	V

Table 10–9. 3.3-V PCI Specifications (Part 2 of 2)

Symbol	Parameter	Conditions	Minimum	Typical	Maximum	Units
V_{IL}	Low-level input voltage		-0.5		$0.3 \times V_{CCIO}$	V
I_I	Input pin leakage current	$0 < V_{IN} < V_{CCIO}$	-10		10	μA
V_{OH}	High-level output voltage	$I_{OUT} = -500 \mu A$	$0.9 \times V_{CCIO}$			V
V_{OL}	Low-level output voltage	$I_{OUT} = 1,500 \mu A$			$0.1 \times V_{CCIO}$	V

Table 10–10. 3.3-V PCI-X Specifications

Symbol	Parameter	Conditions	Minimum	Typical	Maximum	Units
V_{CCIO}	Output supply voltage		3.0	3.3	3.6	V
V_{IH}	High-level input voltage		$0.5 \times V_{CCIO}$		$V_{CCIO} + 0.5$	V
V_{IL}	Low-level input voltage		-0.5		$0.35 \times V_{CCIO}$	V
V_{IPU}	Input pull-up voltage		$0.7 \times V_{CCIO}$			V
I_{IL}	Input pin leakage current	$0 < V_{IN} < V_{CCIO}$	-10.0		10.0	μA
V_{OH}	High-level output voltage	$I_{OUT} = -500 \mu A$	$0.9 \times V_{CCIO}$			V
V_{OL}	Low-level output voltage	$I_{OUT} = 1500 \mu A$			$0.1 \times V_{CCIO}$	V
L_{PIN}	Pin Inductance				15.0	nH

Table 10–11. 3.3-V LVDS I/O Specifications (Part 1 of 2)

Symbol	Parameter	Conditions	Minimum	Typical	Maximum	Units
V_{CCIO}	I/O supply voltage		3.135	3.3	3.465	V
V_{OD}	Differential output voltage	$R_L = 100 \Omega$	250		450	mV
V_{OD}	Change in VOD between high and low	$R_L = 100 \Omega$			50	mV
V_{OS}	Output offset voltage	$R_L = 100 \Omega$	1.125	1.25	1.375	V

Table 10–11. 3.3-V LVDS I/O Specifications (Part 2 of 2)

Symbol	Parameter	Conditions	Minimum	Typical	Maximum	Units
V_{OS}	Change in VOS between high and low	$R_L = 100 \Omega$			50	mV
V_{TH}	Differential input threshold	$V_{CM} = 1.2 V$	-100		100	mV
V_{IN}	Receiver input voltage range		0.0		2.4	V
R_L	Receiver differential input resistor (external to APEX 20K devices)		90	100	110	Ω

Table 10–12. GTL+ I/O Specifications

Symbol	Parameter	Conditions	Minimum	Typical	Maximum	Units
V_{TT}	Termination voltage		1.35	1.5	1.65	V
V_{REF}	Reference voltage		0.88	1.0	1.12	V
V_{IH}	High-level input voltage		$V_{REF} + 0.1$			V
V_{IL}	Low-level input voltage				$V_{REF} - 0.1$	V
V_{OL}	Low-level output voltage	$I_{OL} = 36 \text{ mA } (2)$			0.65	V

Table 10–13. SSTL-2 Class I Specifications (Part 1 of 2)

Symbol	Parameter	Conditions	Minimum	Typical	Maximum	Units
V_{CCIO}	I/O supply voltage		2.375	2.5	2.625	V
V_{TT}	Termination voltage		$V_{REF} - 0.04$	V_{REF}	$V_{REF} + 0.04$	V
V_{REF}	Reference voltage		1.15	1.25	1.35	V
V_{IH}	High-level input voltage		$V_{REF} + 0.18$		$V_{CCIO} + 0.3$	V
V_{IL}	Low-level input voltage		-0.3		$V_{REF} - 0.18$	V

Table 10–13. SSTL-2 Class I Specifications (Part 2 of 2)

Symbol	Parameter	Conditions	Minimum	Typical	Maximum	Units
V_{OH}	High-level output voltage	$I_{OH} = -7.6 \text{ mA}$ (1)	$V_{TT} + 0.57$			V
V_{OL}	Low-level output voltage	$I_{OL} = 7.6 \text{ mA}$ (2)			$V_{TT} - 0.57$	V

Table 10–14. SSTL-2 Class II Specifications

Symbol	Parameter	Conditions	Minimum	Typical	Maximum	Units
V_{CCIO}	I/O supply voltage		2.375	2.5	2.625	V
V_{TT}	Termination voltage		$V_{REF} - 0.04$	V_{REF}	$V_{REF} + 0.04$	V
V_{REF}	Reference voltage		1.15	1.25	1.35	V
V_{IH}	High-level input voltage		$V_{REF} + 0.18$		$V_{CCIO} + 0.3$	V
V_{IL}	Low-level input voltage		-0.3		$V_{REF} - 0.18$	V
V_{OH}	High-level output voltage	$I_{OH} = -15.2 \text{ mA}$ (1)	$V_{TT} + 0.76$			V
V_{OL}	Low-level output voltage	$I_{OL} = 15.2 \text{ mA}$ (2)			$V_{TT} - 0.76$	V

Table 10–15. SSTL-3 Class I Specifications

Symbol	Parameter	Conditions	Minimum	Typical	Maximum	Units
V_{CCIO}	I/O supply voltage		3.0	3.3	3.6	V
V_{TT}	Termination voltage		$V_{REF} - 0.05$	V_{REF}	$V_{REF} + 0.05$	V
V_{REF}	Reference voltage		1.3	1.5	1.7	V
V_{IH}	High-level input voltage		$V_{REF} + 0.2$		$V_{CCIO} + 0.3$	V
V_{IL}	Low-level input voltage		-0.3		$V_{REF} - 0.2$	V
V_{OH}	High-level output voltage	$I_{OH} = -8 \text{ mA}$ (1)	$V_{TT} + 0.6$			V
V_{OL}	Low-level output voltage	$I_{OL} = 8 \text{ mA}$ (2)			$V_{TT} - 0.6$	V

Table 10–16. SSTL-3 Class II Specifications

Symbol	Parameter	Conditions	Minimum	Typical	Maximum	Units
V_{CCIO}	I/O supply voltage		3.0	3.3	3.6	V
V_{TT}	Termination voltage		$V_{REF} - 0.05$	V_{REF}	$V_{REF} + 0.05$	V
V_{REF}	Reference voltage		1.3	1.5	1.7	V
V_{IH}	High-level input voltage		$V_{REF} + 0.2$		$V_{CCIO} + 0.3$	V
V_{IL}	Low-level input voltage		-0.3		$V_{REF} - 0.2$	V
V_{OH}	High-level output voltage	$I_{OH} = -16 \text{ mA}$ (1)	$V_{TT} + 0.8$			V
V_{OL}	Low-level output voltage	$I_{OL} = 16 \text{ mA}$ (2)			$V_{TT} - 0.8$	V

Table 10–17. HSTL Class I I/O Specifications

Symbol	Parameter	Conditions	Minimum	Typical	Maximum	Units
V_{CCIO}	I/O supply voltage		1.71	1.8	1.89	V
V_{TT}	Termination voltage		$V_{REF} - 0.05$	V_{REF}	$V_{REF} + 0.05$	V
V_{REF}	Reference voltage		0.68	0.75	0.90	V
V_{IH}	High-level input voltage		$V_{REF} + 0.1$		$V_{CCIO} + 0.3$	V
V_{IL}	Low-level input voltage		-0.3		$V_{REF} - 0.1$	V
V_{OH}	High-level output voltage	$I_{OH} = -8 \text{ mA}$ (1)	$V_{CCIO} - 0.4$			V
V_{OL}	Low-level output voltage	$I_{OL} = 8 \text{ mA}$ (2)			0.4	V

Table 10–18. LVPECL Specifications (Part 1 of 2)

Symbol	Parameter	Minimum	Typical	Maximum	Units
V_{CCIO}	Output Supply Voltage	3.135	3.3	3.465	V
V_{IH}	Low-level input voltage	1,300		1,700	mV
V_{IL}	High-level input voltage	2,100		2,600	mV
V_{OH}	Low-level output voltage	1,450		1,650	mV

Table 10–18. LVPECL Specifications (Part 2 of 2)

Symbol	Parameter	Minimum	Typical	Maximum	Units
V_{OL}	High-level output voltage	2,275		2,420	mV
V_{ID}	Input voltage differential	400	600	950	mV
V_{OD}	Output voltage differential	625	800	950	mV
t_r, t_f	Rise and fall time (20 to 80%)	85		325	ps
t_{DSKEW}	Differential skew			25	ps
t_O	Output load		150		Ω
R_L	Receiver differential input resistor		100		Ω

Table 10–19. 3.3-V AGP I/O Specifications

Symbol	Parameter	Conditions	Minimum	Typical	Maximum	Units
V_{CCIO}	I/O supply voltage		3.15	3.3	3.45	V
V_{REF}	Reference voltage		$0.39 \times V_{CCIO}$		$0.41 \times V_{CCIO}$	V
V_{IH}	High-level input voltage		$0.5 \times V_{CCIO}$		$V_{CCIO} + 0.5$	V
V_{IL}	Low-level input voltage				$0.3 \times V_{CCIO}$	V
V_{OH}	High-level output voltage	$I_{OUT} = -500 \mu A$	$0.9 \times V_{CCIO}$		3.6	V
V_{OL}	Low-level output voltage	$I_{OUT} = 1500 \mu A$			$0.1 \times V_{CCIO}$	V
I_I	Input pin leakage current	$0 < V_{IN} < V_{CCIO}$	-10		10	μA

Table 10–20. CTT I/O Specifications (Part 1 of 2)

Symbol	Parameter	Conditions	Minimum	Typical	Maximum	Units
V_{CCIO}	I/O supply voltage		3.0	3.3	3.6	V
V_{TT}/V_{REF} (3)	Termination and reference voltage		1.35	1.5	1.65	V
V_{IH}	High-level input voltage		$V_{REF} + 0.2$			V

Table 10–20. CTT I/O Specifications (Part 2 of 2)

Symbol	Parameter	Conditions	Minimum	Typical	Maximum	Units
V_{IL}	Low-level input voltage				$V_{REF} - 0.2$	V
I_i	Input pin leakage current	$0 < V_{IN} < V_{CCIO}$	-10		10	μA
V_{OH}	High-level output voltage	$I_{OH} = -8 \text{ mA}$ (1)	$V_{REF} + 0.4$			V
V_{OL}	Low-level output voltage	$I_{OL} = 8 \text{ mA}$ (2)			$V_{REF} - 0.4$	V
I_o	Output leakage current (when output is high Z)	$GND \leq V_{OUT} \leq V_{CCIO}$	-10		10	μA

Notes to Tables 10–5 through 10–20:

- (1) The I_{OH} parameter refers to high-level output current.
- (2) The I_{OL} parameter refers to low-level output current. This parameter applies to open-drain pins as well as output pins.
- (3) V_{REF} specifies center point of switching range.

Figure 10-1 shows the output drive characteristics of HardCopy APEX devices.

Figure 10-1. Output Drive Characteristics of HardCopy APEX Devices

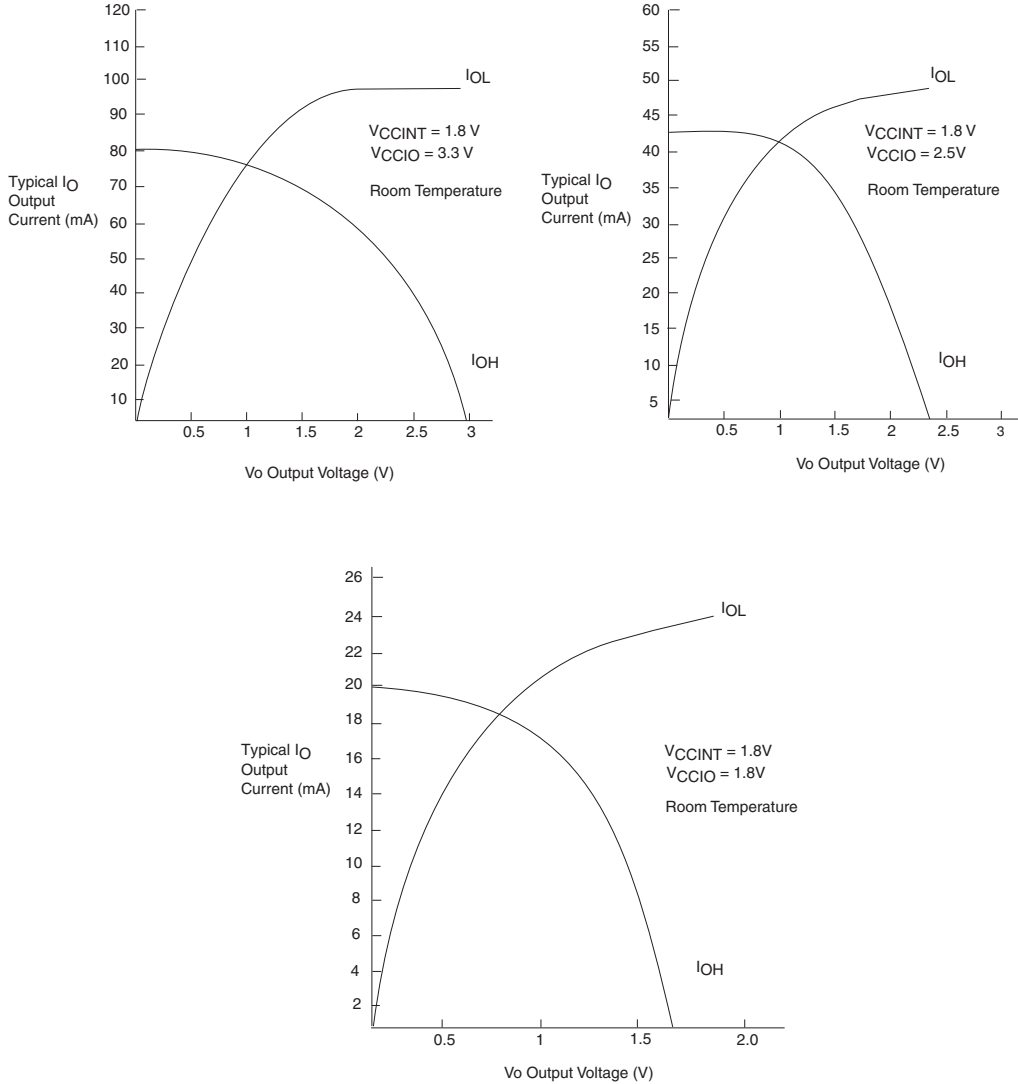
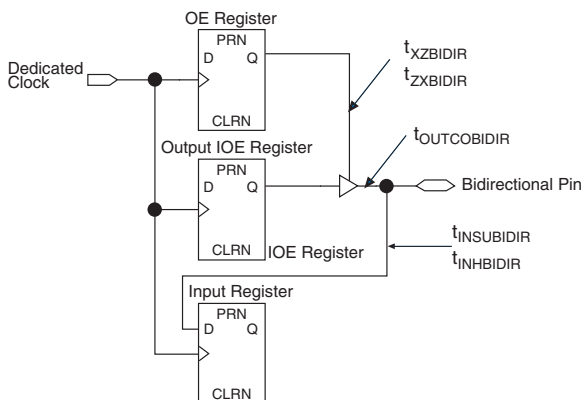

Figure 10–2 shows the timing model for bidirectional I/O pin timing.

Figure 10–2. Synchronous Bidirectional Pin External Timing



Tables 10–21 and 10–22 describe HardCopy APEX device external timing parameters.

Table 10–21. HardCopy APEX Device External Timing Parameters *Note (1)*

Symbol	Clock Parameter	Conditions
t_{INSU}	Setup time with global clock at IOE register	
t_{INH}	Hold time with global clock at IOE register	
t_{OUTCO}	Clock-to-output delay with global clock at IOE output register	C1 = 35 pF
$t_{INSUPLL}$	Setup time with PLL clock at IOE input register	
t_{INHPLL}	Hold time with PLL clock at IOE input register	
$t_{OUTCOPLL}$	Clock-to-output delay with PLL clock at IOE output register	C1 = 35 pF

Table 10–22. HardCopy APEX Device External Bidirectional Timing Parameters (Part 1 of 2) *Note (1)*

Symbol	Parameter	Condition
$t_{INSUBIDIR}$	Setup time for bidirectional pins with global clock at LAB-adjacent input register	
$t_{INHIDIR}$	Hold time for bidirectional pins with global clock at LAB-adjacent input register	
$t_{OUTCOBIDIR}$	Clock-to-output delay for bidirectional pins with global clock at IOE register	C1 = 35 pF
$t_{XZBIDIR}$	Synchronous output enable register to output buffer disable delay	C1 = 35 pF

Table 10–22. HardCopy APEX Device External Bidirectional Timing Parameters (Part 2 of 2) Note (1)

Symbol	Parameter	Condition
$t_{ZXBIDIR}$	Synchronous output enable register to output buffer enable delay	C1 = 35 pF
$t_{INSUBIDIRPLL}$	Setup time for bidirectional pins with PLL clock at LAB-adjacent input register	
$t_{INHIDIRPLL}$	Hold time for bidirectional pins with PLL clock at LAB-adjacent input register	
$t_{OUTCOBIDIRPLL}$	Clock-to-output delay for bidirectional pins with PLL clock at IOE register	C1 = 35 pF
$t_{XZBIDIRPLL}$	Synchronous output enable register to output buffer disable delay with PLL	C1 = 35 pF
$t_{ZXBIDIRPLL}$	Synchronous output enable register to output buffer enable delay with PLL	C1 = 35 pF

Note to Tables 10–21 and 10–22:

- (1) These timing parameters are sample-tested only.

Tables 10–23 and 10–24 show the external timing parameters for HC20K1500 devices.

Table 10–23. HC20K1500 External Timing Parameters Note (1)

Symbol	Min	Max	Unit
t_{INSU}	2.0		ns
t_{INH}	0.0		ns
t_{OUTCO}	2.0	5.0	ns
$t_{INSUPLL}$	3.3		ns
t_{INHPLL}	0.0		ns
$t_{OUTCOPLL}$	0.5	2.1	ns

Table 10–24. HC20K1500 External Bidirectional Timing Parameters (Part 1 of 2) Note (1)

Symbol	Min	Max	Unit
$t_{INSUBIDIR}$	1.9		ns
$t_{INHIDIR}$	0.0		ns
$t_{OUTCOBIDIR}$	2.0	5.0	ns
$t_{XZBIDIR}$		7.1	ns
$t_{ZXBIDIR}$		7.1	ns
$t_{INSUBIDIRPLL}$	3.9		ns

Table 10–24. HC20K1500 External Bidirectional Timing Parameters (Part 2 of 2) Note (1)

Symbol	Min	Max	Unit
$t_{INHDIRPLL}$	0.0		ns
$t_{OUTCOBIDIRPLL}$	0.5	2.1	ns
$t_{XZBIDIRPLL}$		4.2	ns
$t_{ZXBIDIRPLL}$		4.2	ns

Note to Tables 10–23 and 10–24:

- (1) Timing information is preliminary. Final timing information will be available in a future version of this data sheet.

Document Revision History

Table 10–25 shows the revision history for this chapter.

Table 10–25. Document Revision History

Date and Document Version	Changes Made	Summary of Changes
September 2008, v2.3	Updated chapter number and metadata.	—
June 2007, v2.2	Minor text edits.	—
December 2006 v2.1	Updated revision history.	—
March 2006	Formerly chapter 12; no content change.	—
January 2005 v2.0	Update device names and other minor textual changes.	—
June 2003 v1.0	Initial release of <i>Operating Conditions</i> , in the HardCopy Device Handbook	—



In Clear Electronics

WWW.IC-1000.COM

THE DATASHEET OF FPGA



www.ic-1000.com



info@ic-1000.com



[+00852-56412601](tel:+00852-56412601)



[+00852-56412601](https://wa.me/0085256412601)



Unit B, 13/F, Shing Lee Commercial Building
No.8 Wing Kut Street, Central HK